

# #upgrade kit

UPG01CRL41260

SKU

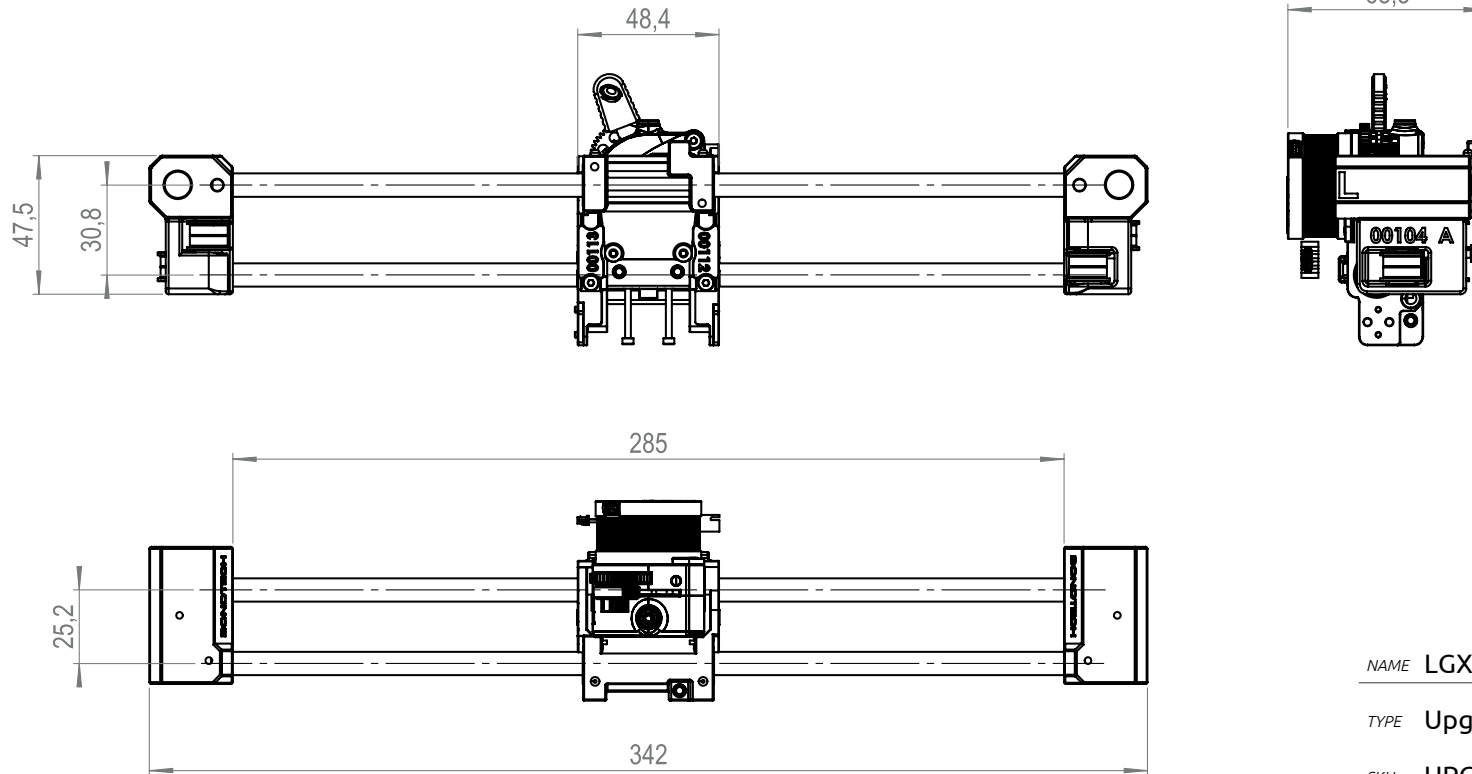

NAME LGX Lite PRO Upgrade Kit for Creality K1 K1C

TYPE Upgrade Kit

SKU UPG01CRL41260

## Specifications

Filament Diameter	1.75mm
Compatible Printer	Creality K1 & K1C
Compatible Hotend	Stock
Includes	LGX Lite Large Gears eXtruder PRO, LGX Lite PRO Accessories For Creality K1 K1C
E-Steps	800 @ 1/16-bit micro stepping 1600 @ 1/32-bit micro stepping
Drive Wheels	Hardened Steel
Top Fitting Tube Od	4.0 mm
Materials Compatibility	Abrasive, rigid, semi-flexible, flexible and soft
Mounting	bottom (2 points); right (2 points), left (2 point), front to motor (3 points),
Max Tightening Torque	0.3Nm
Housing	PA 12 GF
Working Temperature	Up to 100°C
Motor Insulation Class	Class-H

## Comments

Klipper rotation distance 4.0
See drawing above for more details about mounting points location and thread dept
SLS printed housings with glass filled Nylon (PA12 GF)
Up to 180°C

## Specifications

Gross Weight	748g
Net Weight	632g
Box Dimensions (LWH)	403 x 78 x 84mm
Tension	Adjustable with 5 fixed positions
Max Peak Current 1.0A	Recommended current 550-650mA
Stepper Motor	Nema14 Round Stepper 22mm Ø36mm
Motor Connector	JST-XH-4-pin connector
Filament Diameter	1.75 mm
Lubrications	Berutox FB22
CE Certified	Yes
RoHS	Yes
REACH	Yes

## Comments

1-2 Rigid Materials. 2-3 Semi-Flexible. 3-5 Flexible/Soft
---

# #upgrade kit

UPG01CRL41260  
SKU

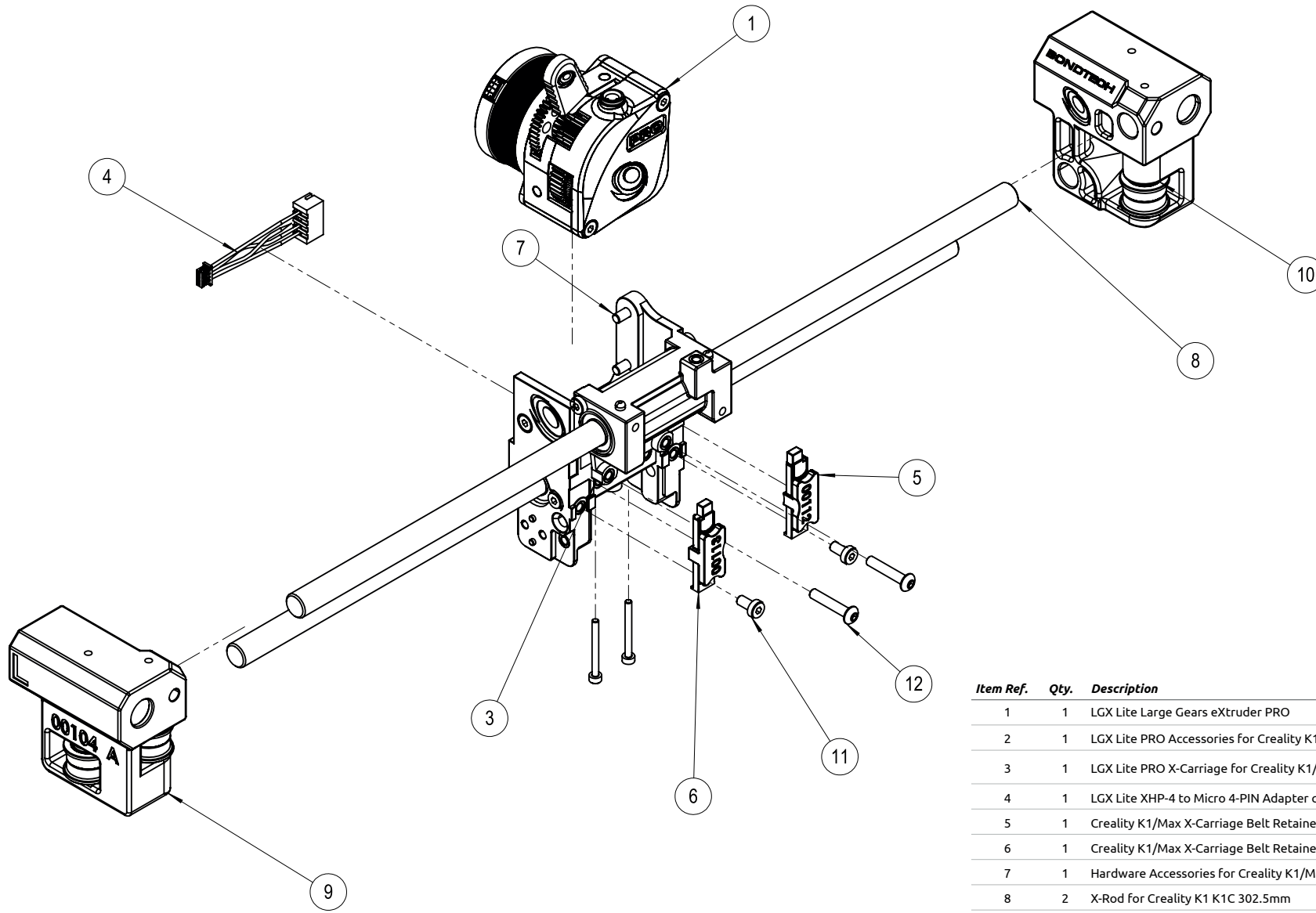

Item Ref.	Qty.	Description	Article Number
1	1	LGX Lite Large Gears eXtruder PRO	EXT01LGX41012
2	1	LGX Lite PRO Accessories for Creality K1 K1C	ACC01CRL41265
3	1	LGX Lite PRO X-Carriage for Creality K1/Max	02PRT61CRG00103
4	1	LGX Lite XHP-4 to Micro 4-PIN Adapter cable	01LCT00CBL00087
5	1	Creality K1/Max X-Carriage Belt Retainer Right	02PRT61HLD00112
6	1	Creality K1/Max X-Carriage Belt Retainer Left	02PRT61HLD00113
7	1	Hardware Accessories for Creality K1/Max	02FST00STS00107
8	2	X-Rod for Creality K1 K1C 302.5mm	01MCH09RDS00110
9	1	X-Rods Holder for Creality K1/Max Left	02PRT61HLD00104
10	1	X-Rods Holder for Creality K1/Max Right	02PRT61HLD00105
11	2	Low Head Cap Screw Black Oxide M3x6	MX3X6L
12	2	Button Head Hex Stainless Steel M3x16	MK6SM3X16

UPGRADE KIT EXPLODED VIEW #02/02